



Intelligent Network (IN)

Definition

An intelligent network (IN) is a service-independent telecommunications network. That is, intelligence is taken out of the switch and placed in computer nodes that are distributed throughout the network. This provides the network operator with the means to develop and control services more efficiently. New capabilities can be rapidly introduced into the network. Once introduced, services are easily customized to meet individual customer's needs.

Overview

This tutorial discusses how the network has evolved from one in which switch-based service logic provided services to one in which service-independent advanced intelligent network (AIN) capabilities allow for service creation and deployment.

As the IN evolves, service providers will be faced with many opportunities and challenges. While the IN provides a network capability to meet the ever-changing needs of customers, network intelligence is becoming increasingly distributed and complicated. For example, third-party service providers will be interconnecting with traditional operating company networks. Local number portability (LNP) presents many issues that can only be resolved in an IN environment to meet government mandates. Also, as competition grows with companies offering telephone services previously denied to them, the IN provides a solution to meet the challenge.

Topics

1. Network Evolution
2. The Introduction of IN
3. Benefits of IN
4. AIN Releases
5. AIN Release 1 Architecture
6. The Call Model

7. AIN Release 0
8. AIN 0.1
9. AIN 0.2
10. AIN Service Creation Examples
11. Other AIN Services
 - Self-Test
 - Correct Answers
 - Glossary

1. Network Evolution

Plain Old Telephone Service (POTS)

Prior to the mid-1960s, the service logic, as shown in *Figure 1*, was hardwired in switching systems. Typically, network operators met with switch vendors, discussed the types of services customers required, negotiated the switching features that provided the services, and finally agreed upon a generic release date for feature availability. After this, the network operator planned for the deployment of the generic feature/service in the switching network fabric.

Figure 1. Plain Old Telephone Service

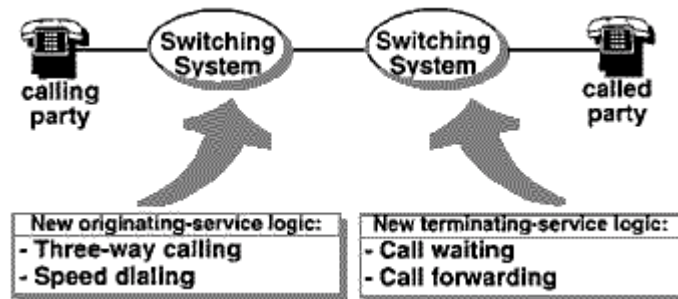

This process was compounded for the network operator with switching systems from multiple vendors. As a result, services were not offered ubiquitously across an operator's serving area. So, a customer in one end of a city, county, or state may not have had the same service offerings as a person in another part of the area.

Also, once services were implemented, they were not easily modified to meet individual customer's requirements. Often, the network operator negotiated the change with the switch vendor. As a result of this process, it took years to plan and implement services.

This approach to new service deployment required detailed management of calling patterns, providing new trunk groups to handle calling patterns. As customer calling habits changed (longer call lengths, larger calling areas, and multiple lines in businesses and residences) the demand on network operators increased.

Stored Program Control (SPC)

In the mid-1960s, stored program control (SPC) switching systems were introduced. SPC was a major step forward because now service logic was programmable where, in the past, the service logic was hardwired. As a result, it was now easier to introduce new services. Nevertheless, this service logic concept was not modular. It became increasingly more complicated to add new services because of the dependency between the service and the service-specific logic. Essentially, service logic that was used for one service could not be used for another service. As a result, if customers were not served by a SPC switching system, new services were not available to them.

Common Channel Signaling Network (CCSN)

Another aspect of the traditional services offerings was the call setup information—that is, the signaling and call supervision that takes place between switching systems and the actual call. When a call was set up, a signal and talk path used the same common trunk from the originating switching system to the terminating switching system. Often there were multiple offices involved in the routing of a call. This process seized the trunks in all of the switching systems involved. Hence, if the terminating end was busy, all of the trunks were set up unnecessarily.

The network took a major leap forward in the mid-1970s with the introduction of the common channel signaling network (CCSN), or SS7 network for short. Signaling system number 7 (SS7) is the protocol that runs over the CCSN. The SS7 network consists of packet data links and packet data switching systems called signaling transfer points (STPs).

The SS7 network (see *Figure 2*) separates the call setup information and talk path from the common trunk that runs between switching systems. The call setup information travels outside the common trunk path over the SS7 network. The type of information transferred included permission for the call setup and whether or not the called party was busy.

Common Channel Signaling

SS7 technology frees up trunk circuits between switching systems for the actual calls. The SS7 network enabled the introduction of new services, such as caller ID.

Caller ID provides the calling party's telephone number, which is transmitted over the SS7 network.

Figure 2. Common Channel Signaling

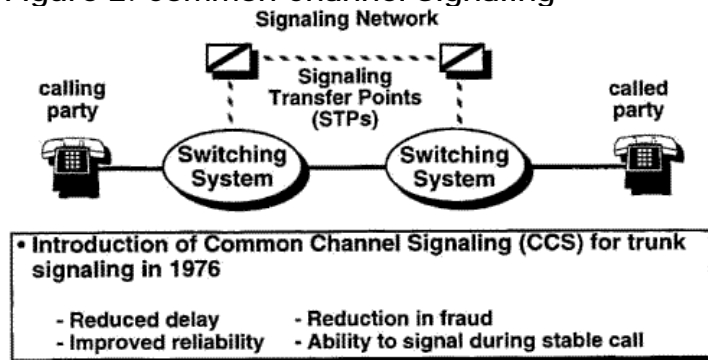

The SS7 network was designed before the IN concept was introduced. However, telephone operators realized that there were many advantages to implementing and using SS7 network capabilities.

2. The Introduction of IN

During the mid-1980s, regional Bell operating companies (RBOCs) began requesting features that met the following objectives:

- rapid deployment of services in the network
- vendor independence and standard interfaces
- opportunities for non-RBOCs to offer services for increased network usage

Telcordia Technologies responded to this request and developed the concept of Intelligent Network 1 (IN/1), shown in *Figure 3*.

Figure 3. Intelligent Network 1 (IN/1)

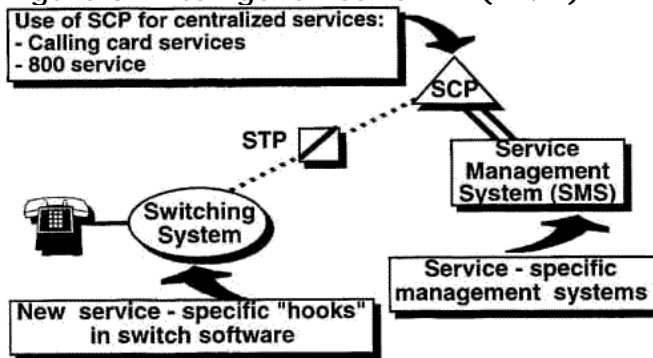

The introduction of the IN/1 marked the first time that service logic was external to switching systems and located in databases called service control points (SCPs). Two services evolved that required IN/1 service logic—the 800 (or Freephone) service and the calling-card verification (or alternate billing service [ABS]). Because of the service specific nature of the technology, these services required two separate SCPs. To communicate with the associated service logic, software was deployed in switching systems. This switching system software enabled the switching system to recognize when it was necessary to communicate with an SCP via the SS7 network.

With the introduction of the SCP concept, new operations and management systems became necessary to support service creation, testing, and provisioning. In the above figure, note the term "service-specific management systems" under the box labeled "service management system." This means that the software-defined hooks or triggers are specific to the associated service. For example, an 800 service has an 800-type trigger at the switching system, an 800-service database at the SCP, and an 800-service management system to support the 800 SCP. In this service-specific environment, the 800-service set of capabilities cannot be used for other services (e.g., 900 service). Although the service logic is external to the switching system, it is still service specific.

Figure 4. AIN Architecture

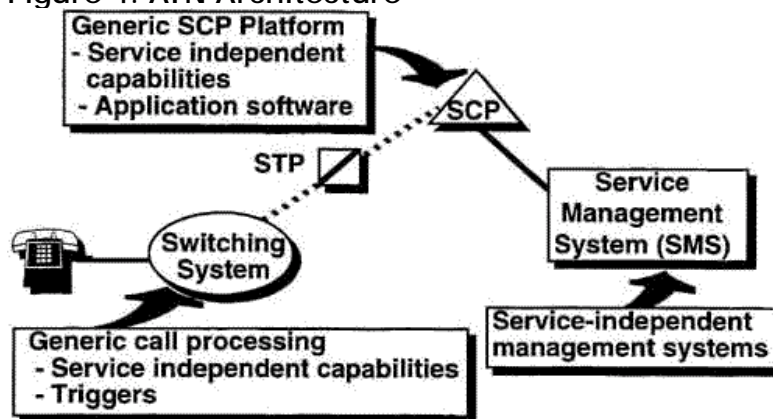

At first glance, *Figure 4* looks similar to *Figure 3*. However, there is one fundamental difference. Notice the wording "service-independent management systems" under the box labeled "service management system." Now, following the IN/1 800 service-specific example, the AIN service-independent software has a three-digit trigger capability that can be used to provide a range of three-digit services (800, 900, XXX, etc.) as opposed to 800 service-specific logic. Likewise, the SCP service logic and the service management system are service-independent, not service specific. AIN is a service-independent network capability!

3. Benefits of Intelligent Networks

The main benefit of intelligent networks is the ability to improve existing services and develop new sources of revenue. To meet these objectives, providers require the ability to accomplish the following:

- **introduce new services rapidly**—IN provides the capability to provision new services or modify existing services throughout the network with physical intervention.
- **provide service customization**—Service providers require the ability to change the service logic rapidly and efficiently. Customers are also demanding control of their own services to meet their individual needs.
- **establish vendor independence**—A major criterion for service providers is that the software must be developed quickly and inexpensively. To accomplish this, suppliers must integrate commercially available software to create the applications required by service providers.
- **create open interfaces**—Open interfaces allow service providers to introduce network elements quickly for individualized customer services. The software must interface with other vendors' products while still maintaining stringent network operations standards. Service providers are no longer relying on one or two vendors to provide equipment and software to meet customer requirements.

AIN technology uses the embedded base of stored program-controlled switching systems and the SS7 network. The AIN technology also allows for the separation of service-specific functions and data from other network resources. This feature reduces the dependency on switching system vendors for software development and delivery schedules. Service providers have more freedom to create and customize services.

The SCP contains programmable service-independent capabilities (or service logic) that are under the control of service providers. The SCP also contains service-specific data that allows service providers and their customers to customize services. With the IN, there is no such thing as one size fits all—services are customized to meet individual needs.

Because service logic is under the service provider's control, it is easier to create services in a cost-effective manner. Network providers can offer market-focused service trials by loading service logic in an SCP and triggering capabilities in one or more switching systems.

Accepted standards and open, well-documented interfaces provide a standard way of communicating between switching systems and SCPs, especially in a multivendor environment.

Local Number Portability

The Telecommunications Act of 1996 is having a profound impact on the U.S. telecommunications industry. One area of impact that is being felt by everyone is local number portability (LNP). For LNP, the Federal Communications Commission (FCC) requires the nation's local exchange carriers (LECs) to allow customers to keep their telephone numbers if they switch local carriers. The LECs must continue to maintain the quality of service and network reliability that the customer always received.

The rules require that all LECs begin a phased deployment of a long-term service-provider portability solution no later than October 1, 1997, in the nation's largest metropolitan statistical areas. This deployment must be completed by December 31, 1998. Incumbent service providers are required to make a number portable within six months after a request is received.

Wireless carriers are also affected by LNP. December 31, 1998, is the date on which wireless carriers must be able to complete a call to a ported wireline number. By June 30, 1999, there must be full portability between wireless and wireline, including roaming capabilities.

AIN is a logical technology to help service providers meet this mandate. Many providers are looking to AIN LNP solutions because of the flexibility that AIN provides without the burden of costly network additions.

For more information on the Telecommunications Act of 1996, visit the FCC's home page on the World Wide Web at <http://www.fcc.gov>.

4. AIN Releases

The demand for AIN services far exceeded the availability of network functionality. Service providers could not wait for all the features and functionality as described in AIN Release 1. AIN Release 1 defined all types of requirements, which made the capability sets too large to be adapted by the industry.

In North America, the industry agreed to develop subsets of AIN Release 1 that provided for a phased evolution to AIN Release 1. AIN 0.1 was the first subset targeted for use in the industry.

Telcordia Technologies developed functionality to address the FTS 2000 requirements set forth by the U.S. government. The RBOCs in turn adapted these requirements to meet their customers' immediate needs. This effort resulted in AIN Release 0, which had a time frame before the availability of AIN 0.1.

Meanwhile, the international standards body, the International Telecommunications Union (ITU), embraced the concepts put forth in the AIN Release 1 requirements. The ITU developed an international IN standard called Capability Set 1, or CS-1. As with AIN Release 1 in North America, CS-1 was all encompassing. To meet the market demand, the ITU formed a subgroup called ETSI to focus on the immediate needs. This subgroup developed the Core INAP capabilities. Many PTTs and their switch vendors have adopted the ETSI Core INAP as the standard and are providing Core INAP capabilities.

The following modules discuss the functionality of various AIN releases, as well as the international standards.

5. AIN Release 1 Architecture

Figure 5 shows the target AIN Release 1 architecture, as defined in Telcordia Technologies AIN Generic Requirements (GRs):

Figure 5. AIN Release 1

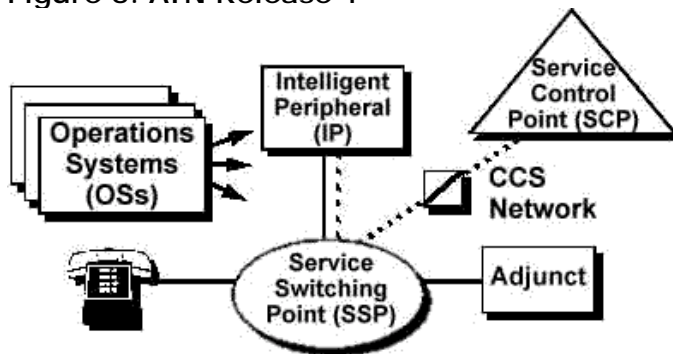

The service switching point (SSP) in this diagram is an AIN-capable switching system. In addition to providing end users with access to the network and performing any necessary switching functionality, the SSP allows access to the set of AIN capabilities. The SSP has the ability to detect requests for AIN-based services and establish communications with the AIN service logic located at the SCPs. The SSP is able to communicate with other network systems (e.g., intelligent peripherals) as defined by the individual services.

The service control point (SCP) provides the service control. There are two basic parts to an SCP. One part is the application functionality in which the service logic is installed after the services have been created. This application functionality sits on top of the second basic SCP part—a set of generic platform

functionalities that are developed by SCP vendors. This platform functionality is shared among the service logic application programs in the application functionality. The platform functionality also provides the SS7 interface to switching systems. As shown in the diagram above, the SCP is connected to SSPs by the SS7 network.

The intelligent peripheral (IP) provides resources such as customized and concatenated voice announcements, voice recognition, and dual-tone multifrequencies (DTMF) digit collection. The IP contains a switching matrix to connect users to these resources. In addition, the IP supports flexible information interactions between an end user and the network. It has the resource management capabilities to search for idle resources, initiate those resources, and then return them to their idle state.

The interface between the SSP and the IP is an integrated services digital network (ISDN), primary rate interface (PRI), and/or basic rate interface (BRI). The IP has the switching functionality that provides the ISDN interface to the switching system.

The adjunct shown in the diagram above is functionally equivalent to an SCP, but it is connected directly to an SSP. A high-speed interface supports the communications between an adjunct and an SSP. The application-layer messages are identical in content to those carried by the SS7 network between the SSP and SCP.

6. The Call Model

The call model is a generic representation of SSP call-processing activities required to establish, maintain, and clear a basic call. The call model consists of point in calls (PICs), detection points (DPs), and triggers. These are depicted in *Figure 6*.

Figure 6. The Call Model: Basic Concept

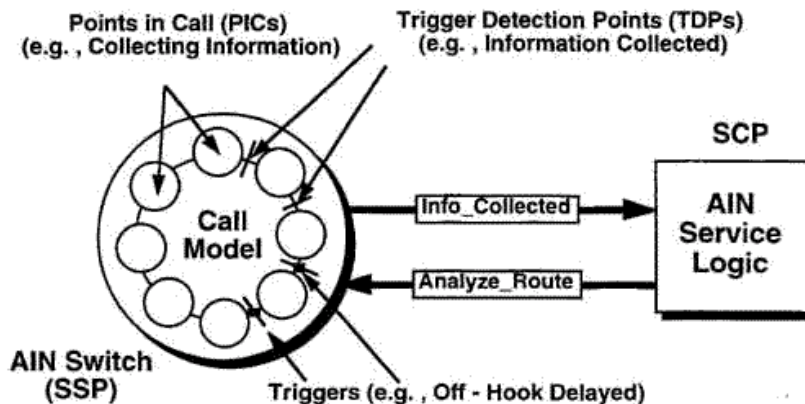

PICs represent the normal switching system activities or states that a call goes through from origination to termination. For example, the null state or the idle state is when the SSP is actually monitoring the customer's line. Other examples of states, or PICs, are off-hook (or origination attempt), collecting information, analyzing information, routing, alerting, etc.

Switching systems went through similar stages before AIN was developed. However, the advent of AIN introduced a formal call model to which all switching systems must adhere. In this new call model, trigger detection points (TDPs) were added between the PICs. SSPs check TDPs to see if there are any active triggers.

There are three types of triggers: subscribed or line-based triggers, group-based triggers, and office-based triggers. Subscribed triggers are provisioned to the customer's line so that any calls originating from or terminating to that line would encounter the trigger. Group-based triggers are assigned to groups of subscribers—e.g., business or Centrex groups. Any member of a software-defined group will encounter the trigger. Office-based triggers are available to everyone who is connected to the telephone switching office or has access to the North American numbering plan. Office-based triggers are not assigned to individuals or groups.

If an active trigger is detected, normal switching system call processing is suspended until the SSP and SCP complete communications. For example, in the diagram above, suppose an AIN call has progressed through the null state or the off-hook PIC and is currently at the collecting-information PIC. Normal call processing is suspended at the information-collected TDP because of an active off-hook delayed trigger. Before progressing to the next (analyze information) PIC, the SSP assembles an information-collected message and sends it to the SCP over the SS7 network. After SCP service logic acts on the message, the SCP sends an analyze-route message that tells the SSP how to handle the call before going to the next PIC (analyze information).

Essentially, when the SSP recognizes that a call has an associated AIN trigger, the SSP suspends the call processing while querying the SCP for call routing instructions. Once the SCP provides the instruction, the SSP continues the call model flow until completion of the call. This is basically how a call model works, and it is an important part of AIN. This concept differs from the pre-AIN switching concept in which calls were processed from origination state to the call-termination state without call suspension.

7. AIN Release 0

The AIN Release 0 call model has three trigger checkpoints (TCPs). At each TCP there one or more triggers. For example, the off-hook TCP includes the off-hook

immediate trigger. If a subscriber's line is equipped with this trigger, communications with the SCP will occur if the switching system detects an off-hook condition. For an off-hook delayed trigger, one or more digits are dialed before triggering to the SCP. At the digit-collection and analysis TCP, collected digits are analyzed before triggering. Triggering may also occur at the routing stage of a call. This call model is shown in *Figure 7*.

Figure 7. AIN Release 0 Call Model

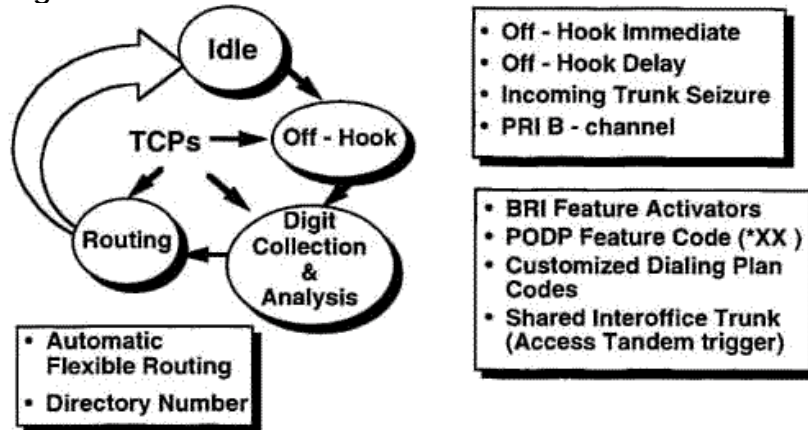

When a switching system recognizes that a call requires AIN involvement, it checks for overload conditions before communicating with the SCP. This process is called code gapping. Code gapping allows the SCP to notify the switching system to throttle back messages for certain NPAs or NPA-NXXs. When code gapping is in effect, some calls may receive final treatment. For others, a provide-instruction message is sent to the SCP. Depending on the SCP service logic, it will respond to the switching system with any of the call-processing instructions shown in the *Figure 8*.

Figure 8. AIN Release 0 Functions

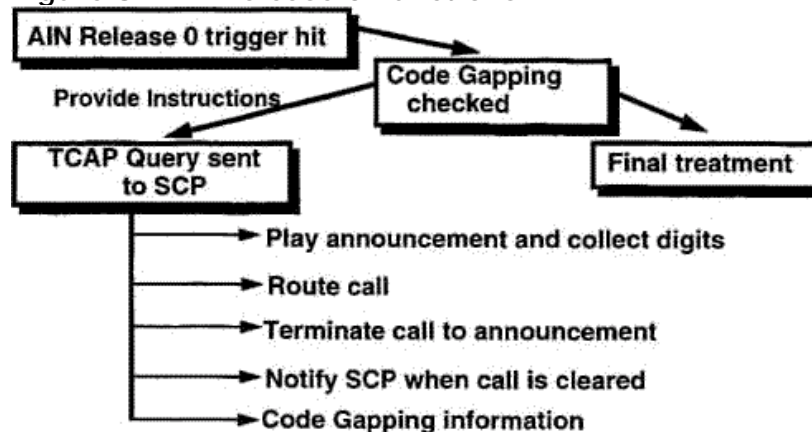

AIN Release 0 provided 75 announcements at the switching system. Release 0 was based on American National Standards Industry (ANSI) Transaction

Capability Application Part (TCAP) issue 1. TCAP is at layer 7 of the SS7 protocol stack. This means that there is only one message sent from the SSP to the SCP, no matter what trigger is hit at any of the three TCPs.

8. AIN Release 0.1

AIN 0.1 is the first subset of AIN Release 1. There are two fundamental differences between AIN Release 0 and AIN 0.1. The first is a formal call model and the second is the messaging sets between the switching system and the SCP. The formal call model is separated into the originating call model (originating half call) and the terminating call model (terminating half call). The AIN Release 0 call model did not distinguish between originating and terminating. A standard or formal call model is necessary as we evolve to the Target AIN Release 1 capability, because the capabilities will have more PICs and TDPs. Also, there will be multiple switch types and network elements involved. Therefore, the service logic will need to interact with every element that will be required in the network.

AIN 0.1 includes several other major features. There are 254 announcements at the switching system, which provides more flexible messages available to customers. There are additional call-related and noncall-related functions as well as three additional triggers—the N11 trigger, the 3-6-10-digit trigger, and the termination attempt trigger. More triggers provide additional opportunities for SCP service logic to influence call processing. (Note: TCP was an AIN Release 0 term that changed to TDP in AIN 0.1).

There are several AIN 0.1 noncall-related capabilities. The SCP has the ability to activate and deactivate subscribed triggers. The AIN 0.1 SCP can also monitor resources. In addition to sending a call routing message to the switching system, the SCP may request that the switching system monitor the busy/idle status of a particular line and report changes. AIN 0.1 also supports standard ISDN capabilities.

As mentioned previously, there is a distinction between the originating side and the terminating side of a service switching point. This means that both originating and terminating triggers and service logic could influence a single call.

Figure 9 shows a portion of the AIN 0.1 originating call model. The AIN 0.1 originating call model includes four originating trigger detection points—origination attempt, information collected, information analyzed, and network busy.

Figure 9. AIN 0.1 Originating Call Model

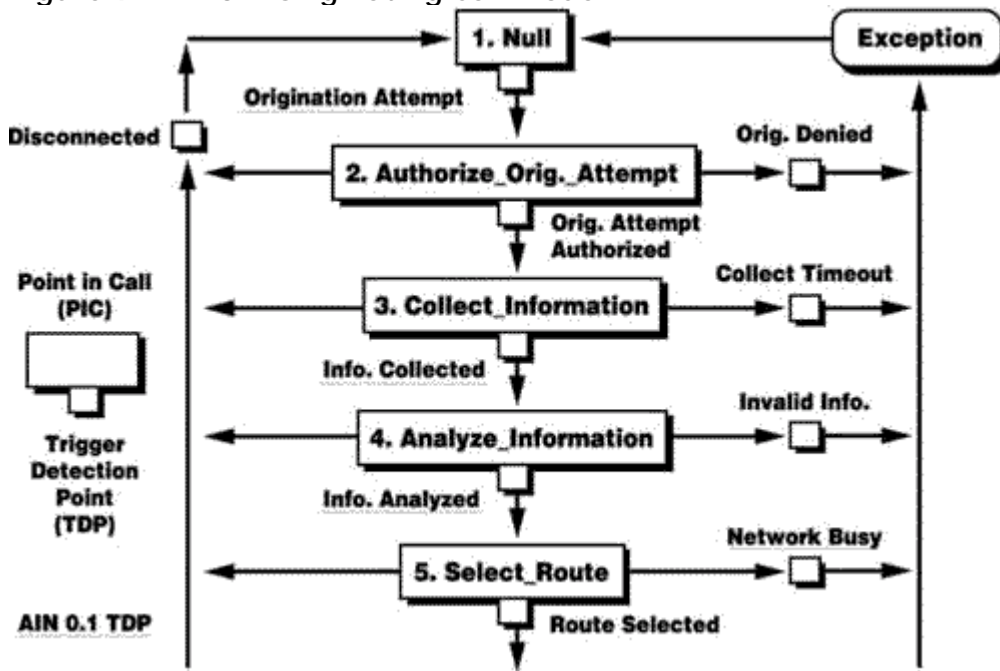

The AIN 0.1 terminating call model includes one TDP—termination attempt, as depicted in the partial call model in *Figure 10*.

Figure 10. AIN 0.1 Terminating Call Model

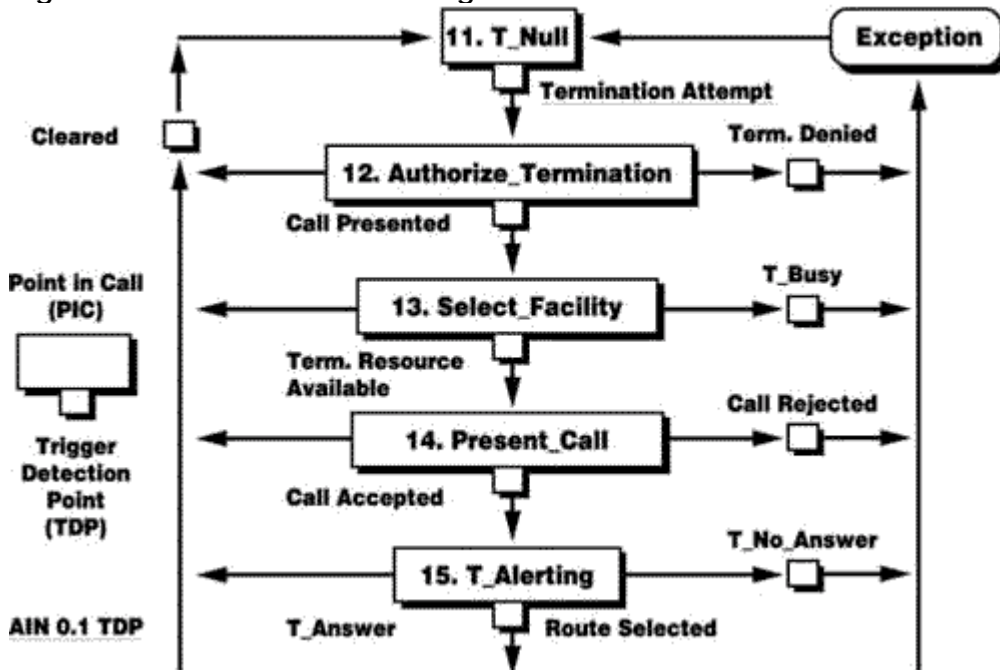

AIN 0.1: SSP–SCP Interface

The AIN 0.1, as shown in *Figure 11*, is based on ANSI TCAP issue 2, which means that the message set is different than the message set in ANSI TCAP issue 1. For example, in AIN Release 0, there is only one message sent from the SSP to the SCP no matter what trigger is hit at any of the three TCPs. In AIN 0.1, separate messages are sent for the four originating and one terminating TDP.

Figure 11. AIN 0.1 SSP–SCP Interface



- **Uses ANSI TCAP Issue 2**
 - **Not backward compatible with AIN 0 SSP - SCP interface that uses ANSI TCAP Issue 1**
- **Functionally aligned with ITU-T IN Capability Set 1**

9. AIN Release 0.2

AIN 0.2 builds on AIN 0.1 with additional capabilities to support two service drivers—phase 2 personal communication service (PCS) and voice-activated dialing (VAD). While AIN 0.2 is focused on capabilities to supports PCS and VAD, all requirements for these capabilities are defined in a service-independent manner. AIN 0.2 capabilities will include the following:

- ISDN–based SSP–IP interface
- busy and no-answer triggers
- next event lists processing
- default routing
- additional functions in all operations areas (e.g., network testing)

The two primary AIN 0.2 capabilities are the ISDN interface between a switching system and an ISDN–capable device (such as an IP) and the addition of busy and no-answer triggers.

Next event lists processing is another important capability. In addition to TDPs, AIN 0.2 includes event detection points (EDPs). With EDPs, the SCP will have the ability to send a next-event list to the SSP. This next-event list is used by the SSP to notify the SCP of events included in the next-event list. These events may include busy, no answer, terminating resource available, etc.

AIN 0.2, also includes default routing capabilities. This means that when calls encounter error conditions, they can be sent to a directory number, an announcement, etc., as opposed to sending it to final treatment, as is the case in AIN 0.1.

AIN 0.2 SSP–IP Interface

AIN Release 0 and AIN 0.1 assumed that the announcements were switch-based. With the introduction of 0.2, announcements can reside in an external database, such as an IP.

If the SCP sends a send-to-resource message to the switching system to have the IP play an announcement or collect digits, the switching system connects the customer to the IP via the SSP–IP ISDN interface. The end user exchanges information with the IP. The IP collects the information and sends it to the switching system. The switching system forwards the information to the SCP. One of the fundamental switching system capabilities is the interworking of SS7 (SCP) messages with ISDN messages (SSP–IP).

In addition the SSP may control IP resources without SCP involvement. VAD is an example. A VAD subscriber could be connected to the IP voice-recognition capabilities upon going off-hook. The VAD subscriber says "call mom," and the IP returns mom's telephone number to the switching system. The switching system recognizes mom's number as if the subscriber had actually dialed the number.

10. AIN Service Creation Examples

The previous modules addressed the architecture and the theory of the AIN. This section will discuss various aspects of service creation—the tool that builds the representation of the call flow for each individual customer. Many AIN software vendors have paired service creation software with state-of-the-art computer graphics software to eliminate the need for traditional programming methods. Through the use of menu-driven software, services are created by inputting various service parameters.

Building-Block Approach

Figure 12 provides an example of a building-block approach to creating AIN services. Play announcement, collect digits, call routing, and number translation building blocks are shown here. The SSP has the ability to play announcement and collect digits, as does the IP. Routing the call is an SSP function, and number translation is an SCP capability. By arranging these four capabilities or building blocks in various combinations, services such as 800 service with interactive dialing, outgoing call screening, and area number calling can be created.

Figure 12. AIN Service Example: Building-Block Approach

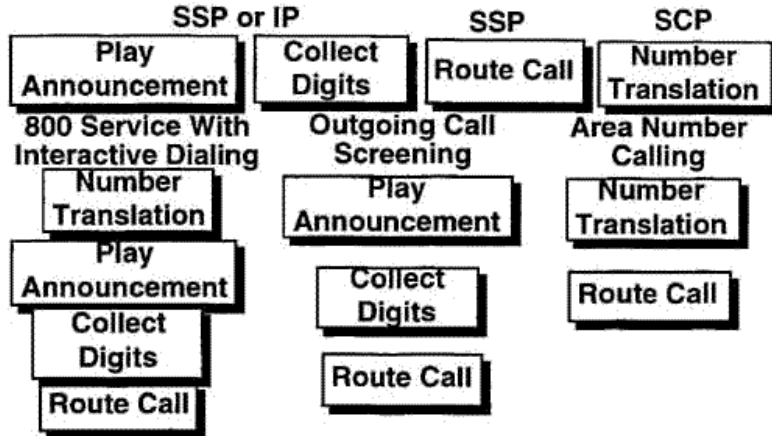

Service Creation Template

Figure 13 represents what a service creation template might look like. For an outgoing call screening service, the service begins with the customer's telephone number. This example allows the customer to screen 900 numbers, while still having the ability to override 900 screening by entering a PIN. Except for 703-974-1234, all non-900 calls are processed without screening.

Figure 13. AIN Service Example: Service Creation Template

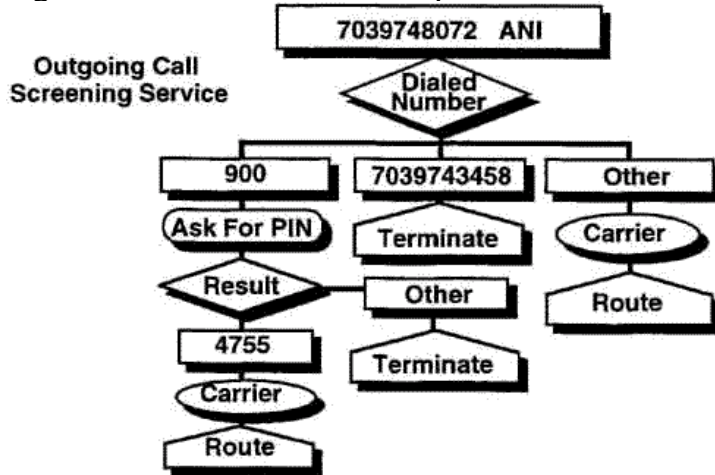

Digit Extension Dialing Service

A four-digit extension dialing service is displayed in Figure 14. It allows for abbreviated dialing beyond central-office (CO) boundaries. If an employee at location 1 wants to call an employee at location 2 by dialing the extension number 111, 2111 would be dialed. Although 2111 is not a number that a switching system can use to route the call, a customized dialing plan trigger is encountered after

2111 is dialed and a query is sent to the SCP. Service logic at the SCP uses the 2111 number to determine the real telephone number of the called party.

Figure 14. AIN Service Example: Digit Extension Dialing Service

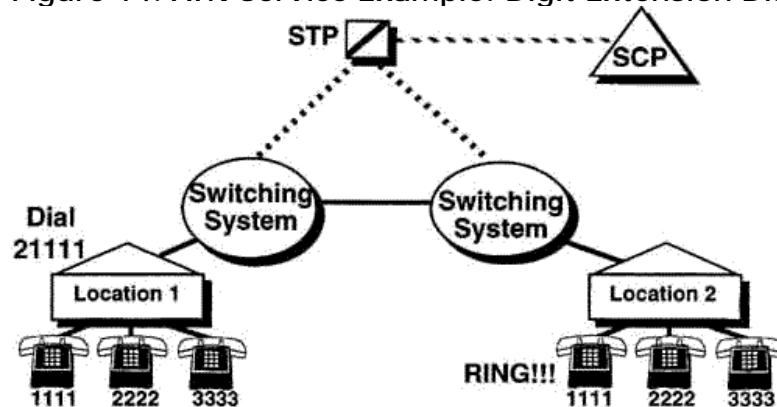

Disaster Recover Service

Figure 15 illustrates a disaster recovery service. This service allows businesses to have calls routed to one or more alternate locations based on customer service logic at the SCP. Calls come into the switching system served by the normal location. After triggering, communication with the SCP occurs. Based on the service logic, the call could be either routed to the normal business location or to one or more alternate business locations.

Figure 15. Disaster Recovery Service

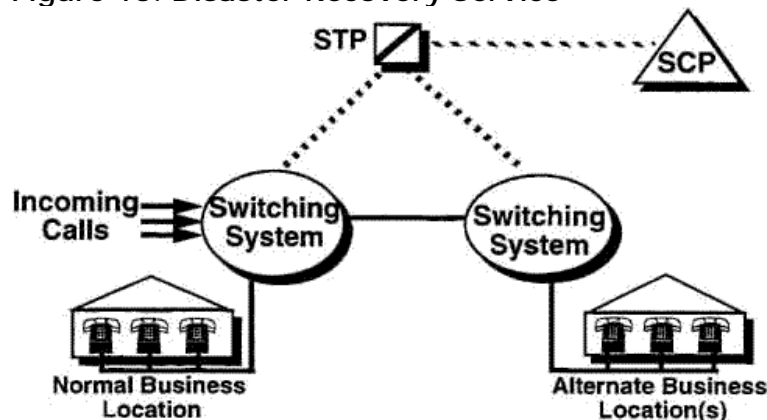

Area Number Calling Service

An area number calling (ANC) service is shown in Figure 16. This service is useful for companies or businesses that want to advertise one telephone number but want their customer's calls routed to the nearest or most convenient business

location. The SCP service logic and data (e.g., zip codes) are used to make a match between the calling party's telephone number and geographic location. The call is then routed to the company or business location that is closest to or most convenient for the calling party.

Figure 16. Area Number Calling (ANC) Service

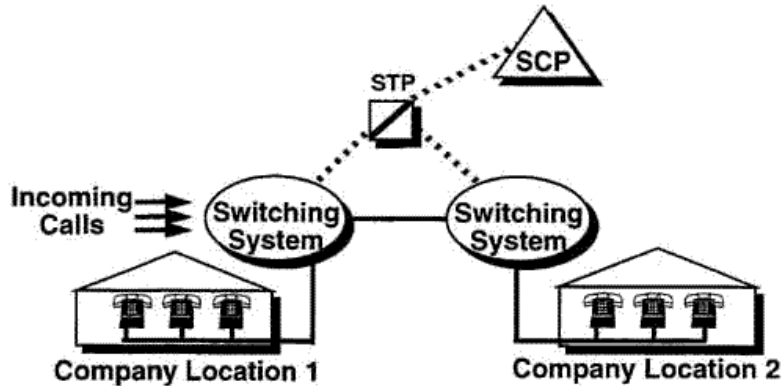

Do-Not-Disturb Service

Finally, *Figure 17* displays a do-not-disturb service. This is a service in which the Smith family has terminating screening service logic at the SCP. Whenever someone calls them, the service logic determines whether the call should be routed to the Smith's telephone or an announcement should be played. In this particular case, a telemarketer calls the Smith family. The SCP tells the switching system to route the telemarketer to an announcement.

Figure 17. Do-Not-Disturb Service

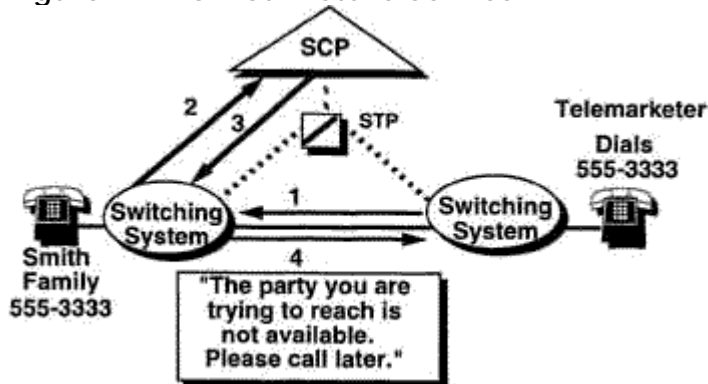

The customers' SCP service logic may also contain a list of numbers that they want to get through while do not disturb is active. In that case, if the SCP finds a match between the calling party number and a number on the list, the call is routed to the Smith family.

11. Other AIN Services

The following list describes the services that companies have developed using AIN/IN technology. Some services are tarified, deployed in the network, and generate revenues. Others are in market or technical trials, getting ready for deployment. There are other services that are either planned for deployment or were developed for demonstration purposes.

- **N11 access service**—With this service, a unique code is used to access a service gateway to information service providers (ISPs), such as newspapers or libraries. The subscriber may either preselect an ISP for automatic routing or request block calls to ISPs.
- **basic routing**—Basic routing function allows the subscriber to route calls to a single destination as defined in the system.
- **single number service**—Routing by single number service allows calls to have different call treatments based on the originating geographic area and the calling party identification.
- **routing by day of week**—The routing by day-of-week function allows the service subscriber to apply variable call routings based on the day of the week that the call is placed.
- **routing by time of day**—The routing by time-of-day function allows service subscribers to apply variable call routings based on the time of the day that the call is made.
- **selective routing**—This service is tied to the call-forwarding feature generally offered as a switch-based feature. With the AIN, when a call to a selective routing customer is forwarded, the SCP determines where to route the forwarded call based on the caller's number.
- **call allocator**—The call allocator service feature allows the service subscriber to specify the percentage of calls to be distributed randomly up to five alternate call handling treatments.
- **alternate destination on busy (ADOB)**—The ADOB service feature allows the service subscriber to specify a sequence of destinations to which calls will be routed if the first destination is busy.
- **command routing**—A service subscriber predefines a set of alternate call treatments to handle traffic in cases of emergency, unanticipated or anticipated demand peaks, or for any other reason that warrants an alternate call treatment.

- **call gate**—This is a versatile out-going call screening service. Call gate supports a personal identification number (PIN) and screening based on time of day and day of week.
- **personal access**—Personal access is a type of "follow me" service. A virtual telephone number is assigned to the personal access service subscriber. When a caller dials this number, the software determines how to route the call.
- **calling party pays**—Calling party pays is a service offered to cellular customers. It notifies the calling party that they are trying to reach a cellular number. If they choose to complete the call, they will incur the connect charge of the called party. If they elect not to incur the cost, the call may either be terminated or routed to called party's voice mail.
- **remote access to call forwarding (Ultraforward)**—The Ultraforward service allows remote access to call forwarding. Callers may, from any location in the world, call in remotely and activate and/or change their call forwarding number.
- **portable number service (PNS)**—PNS features enhanced call forwarding for large business subscribers. It provides subscribers with the ability to maintain a personal itinerary which includes time-of-day, day-of-week (TOD/DOW) schedules, call searching schedules, and call routing information. PNS subscribers also have the ability to override their schedules with default routing instructions. This service is intended for companies with employees who are in highly mobile environments requiring immediate availability.
- **enhanced 800 service (Freephone)**—A customer's call to an 800-service subscriber can be routed to different destinations, instances of routing include the geographic location of the caller, the time and day the call is made, and the caller responses to prompts. The subscriber sets alternate routing parameters for the call if the destination is busy or unavailable, thereby redirecting and allowing for completion of the call.
- **mass calling service (MCS)**—MCS is a polling and information service that permits simultaneous calling by a large number of callers to one or more telephone numbers. MCS provides a variety of announcement-related services that connect a large number of callers (who dial an advertised number) to recorded announcement devices. Two types of offerings are mass announcements, such as time and weather, and televoting, which allows callers to register their opinions on a topic of general interest.

- **automatic route selection/least cost routing**—With this service, subscribers design a priority route for every telephone number dialed. The system either directs calls or blocks calls to restricted privilege users.
- **work-at-home**—This service allows an individual to be reached at home by dialing an office number, as well as allowing the employee to dial an access code from home, make long-distance calls, and have them billed and tracked to a business telephone number.
- **inmate service**—This service routes prisoners' calls, tracks the call information, and offers call control features such as prompts for personal identification numbers, blocking certain called numbers and time or day restrictions.
- **holding room**—Transportation companies' passengers use this service to inform families or business associates of transportation delays or cancellations.
- **call prompter**—The call prompter service feature allows a service subscriber to provide an announcement that requests the caller to enter a digit or series of digits via a dual tone multifrequency (DTMF) telephone. These digits provide information that are used to direct routing or as a security check during call processing.
- **call counter**—The call counter service feature increases a counter in the televoting (TV) counting application when a call is made to a TV number. The counts are managed in the SCP, which can accumulate and send the results during a specific time period.
- **500 access service**—This routing service allows personal communications service (PCS) providers the ability to route calls to subscribers who use a virtual 500 number.
- **PBX extend service**—This service provides a simple way for users to gain access to the Internet network.
- **advertising effectiveness service**—This service collects information on incoming calls (for example, ANI, time, and date). This information is useful to advertisers to determine the demographics of their customers.
- **virtual foreign exchange service**—uses the public switched network to provide the same service as wired foreign exchange service.

- **automated customer name and address (ACNA)**—ACNA enables customers to block their lines from being accessed by the service.
- **AIN for the case teams (ACT)**—ACT allows technicians to dial from a customer premise location anywhere in the service region and connect to a service representative supported by an ACD. Through voice prompts, the technician is guided to the specific representative within a case team pool within seconds, with no toll charges to the customer.
- **regional intercept**—Regional intercept instructs callers of new telephone numbers and locations of regional customers. This service also forwards calls to the new telephone number of the subscriber. Various levels of the service can be offered, based upon the customer's selection.
- **work-at-home billing**—A person who is working at home dials a 4-digit feature access code, which prompts the system to track and record the billing information for the calls. Calls tracked in this manner are billed directly to the company rather than to the individual.
- **inbound call restriction**—This service allows a customer to restrict certain calls from coming into the subscriber's location. This service is flexible enough to restrict calls either by area code, NNX, or particular telephone numbers. Restrictions may even be specified by day of week or time of day.
- **outbound call restriction**—This service allows a customer to restrict certain calls from being completed from the subscriber's location. This service is flexible enough to restrict calls by either area code, NNX, or particular telephone numbers. Restrictions may even be specific to day of week or time of day.
- **flexible hot line**—This service allows a customer to pick up a telephone handset and automatically connect to a merchant without dialing any digits. An example of this is a rent-a-car phone in an airport, which allows a customer to notify the rent-a-car company to pick them up at the terminal.

This list of services is only a sample of the potential that IN technology offers the industry. Everyone benefits!

1. The network provider reuses embedded plant.
2. The service provider provides services to the marketplace faster.

3. The customer customizes their services to meet their particular needs.

Self-Test

1. One of the major advances that result from implementing intelligent networks is that _____.
 - a. computers no longer have control over the network
 - b. wide-area service outages are much less likely
 - c. services can be adapted to user needs more efficiently
 - d. service providers are now limited to a single equipment provider
2. At each trigger detection point (TDP), the AIN component that checks for active triggers is the _____.
 - a. SSP
 - b. SCP
 - c. STP
 - d. PCP
3. There are three types of triggers _____.
 - a. subscribed, group-based, trunk
 - b. subscribed, trunk, office-based
 - c. subscribed, group-based, office-based
 - d. trunk, group-based, office-based
4. A service control point (SCP) is _____.
 - a. a switch that is controlled by the intelligent network
 - b. a database for various IN services
 - c. a series of triggers that initiate controller actions
 - d. an instance in time at which the network selects a service to initiate

5. The development of the intelligent network places increased emphasis on a consistent _____.
 - a. switch model
 - b. network model
 - c. intelligence model
 - d. call model

6. To say that a network is intelligent means that it is _____.
 - a. able to make decisions on its own
 - b. controlled by software on distributed computers
 - c. able to bridge the gap between user and supplier needs
 - d. controlled by microchips that are easily interchanged

7. Trigger check point (TCP) is a more recent term for trigger detection point.
 - a. true
 - b. false

8. When a switching system checks for overload conditions before communicating with the SCP, the process is called "trigger delay."
 - a. true
 - b. false

9. The distinction between the originating side and the terminating side of a service switching point (SSP) means that both originating and terminating triggers could influence the same call.
 - a. true
 - b. false

10. The major functions of the service switching point (SSP) are to provide network access, perform necessary switching, and allow access to AIN capabilities.
 - a. true

- b. false
11. The call model is a generic representation of the call-processing activities necessary to establish, maintain, and clear a basic call.
- a. true
 - b. false
12. The building-block approach to creating AIN services is based on the AIN's ability to add groups or blocks of users to the network without interruption of service.
- a. true
 - b. false

Correct Answers

1. One of the major advances that result from implementing intelligent networks is that _____.
- a. computers no longer have control over the network
 - b. wide-area service outages are much less likely
 - c. services can be adapted to user needs more efficiently**
 - d. service providers are now limited to a single equipment provider
2. At each trigger detection point (TDP), the AIN component that checks for active triggers is the _____.
- a. SSP**
 - b. SCP
 - c. STP
 - d. PCP
3. There are three types of triggers _____.
- a. subscribed, group-based, trunk
 - b. subscribed, trunk, office-based

- c. subscribed, group-based, office-based**
 - d. trunk, group-based, office-based
- 4. A service control point (SCP) is _____.
 - a. a switch that is controlled by the intelligent network
 - b. a database for various IN services**
 - c. a series of triggers that initiate controller actions
 - d. an instance in time at which the network selects a service to initiate
- 5. The development of the intelligent network places increased emphasis on a consistent _____.
 - a. switch model
 - b. network model
 - c. intelligence model
 - d. call model**
- 6. To say that a network is intelligent means that it is _____.
 - a. able to make decisions on its own**
 - b. controlled by software on distributed computers
 - c. able to bridge the gap between user and supplier needs
 - d. controlled by microchips that are easily interchanged
- 7. Trigger check point (TCP) is a more recent term for trigger detection point.
 - a. true**
 - b. false
- 8. When a switching system checks for overload conditions before communicating with the SCP, the process is called "trigger delay."
 - a. true
 - b. false**

9. The distinction between the originating side and the terminating side of a service switching point (SSP) means that both originating and terminating triggers could influence the same call.
- a. true**
 - b. false
10. The major functions of the service switching point (SSP) are to provide network access, perform necessary switching, and allow access to AIN capabilities.
- a. true**
 - b. false
11. The call model is a generic representation of the call-processing activities necessary to establish, maintain, and clear a basic call.
- a. true**
 - b. false
12. The building-block approach to creating AIN services is based on the AIN's ability to add groups or blocks of users to the network without interruption of service.
- a. true
 - b. false**

Glossary

AIN

advanced intelligent network

AMP

AIN maintenance parameter

API

applications programming interface

ASE

application service elements

BCSM

basic call state model

BRI

basic rate interface

BSTP

broadband signaling transfer point

CCM

call control module

CFM

call failure message

CSM

call segment model

DAA

directory assistance automation

DAP

data access point

DCN

data communications network

DP

detection point

EDP

event detection point

EML

element management layer

ETC

event trapping capability

FE

functional entity

GDI

generic data interface

IF

information flow

IN

intelligent network

INAP

intelligent network application protocol

IN/1

intelligent network 1

IP

intelligent peripheral

IPC

intelligent peripheral controller

IPI

intelligent peripheral interface

ISCP

integrated service control point

LIDB

line information database

LNP

local number portability

MP

mediation point

MSC

message sequence chart

NAP

network access point

NCAS

noncall associated signaling

NCP

network control point

NE

network element

NEL

next event list

NML

network management layer

NNI

network-to-network interface

OBCM

originating basic call model

ONA

open network architecture

OOP

object-oriented programming

OPC

originating point code

PCS

personal communications service

PIC

points in call

PP

physical plane

RDC

routing determination check

RE

resource element

RVT

routing verification test

SCE

service creation environment

SCMS

service creation and maintenance system

SCP

service control point

SDP

service data point

SIBB

service-independent building block

SLE

service logic editor

SLEE

service logic execution environment

SLI

service logic interpreter

SLL

service logic language

SLP

service logic program

SM

session management

SMS

service management system

SN

service node

SOP

service order provisioning

SP

service plane

SSP

service switching point

STP

signaling transfer point

TBCM

terminating basic call model

TCP

trigger check point

TCP

test call parameter

TDP

trigger detection point

TSC

trigger status capability

WIN

wireless intelligent network