

CS 378 – Big Data Programming

Lecture 13

more on

Data Organization Patterns

Review

- Assignment 6 – User Session
- Questions/Issues?
 - AVRO field definitions
 - Input parsing
 - Output

Assignment 6

- Define an Avro object for user session
 - One user session for each unique userID
 - Session will include an array of events
 - Events ordered by timestamp
- Identify data associated with the session as a whole
- Identify data associated with individual events
- Include all the fields in the log entries
- Create enums where requested

Data Organization Patterns

- Structured to hierarchical pattern
 - User session is one such example
 - Organizing web logs by user
 - Textbook shows organizing posts and comments from StackOverflow

Partitioning

- Organize “similar” records into partitions
- Why?
 - Future jobs will only focus on subsets of the data
- Partitioning schemes:
 - Time: hour, day, week, month, year
 - Geography: ZIP, DMA, state, time zone, country
 - Data source: web site
 - Data type

Partitioning

- No downside, as a mapReduce job can run over all partitions if needed
 - Note: Avoid creating many small files
- We do need to know *a priori* how many partitions we want
 - Can run a job that scans and summarizes the data
 - Get possible values, and counts
 - Just like we did for user sessions

Partitioning

- What are some of the ways we might partition our user sessions?

- How would we do this?

MapReduce in Hadoop

Figure 2.4, Hadoop - The Definitive Guide

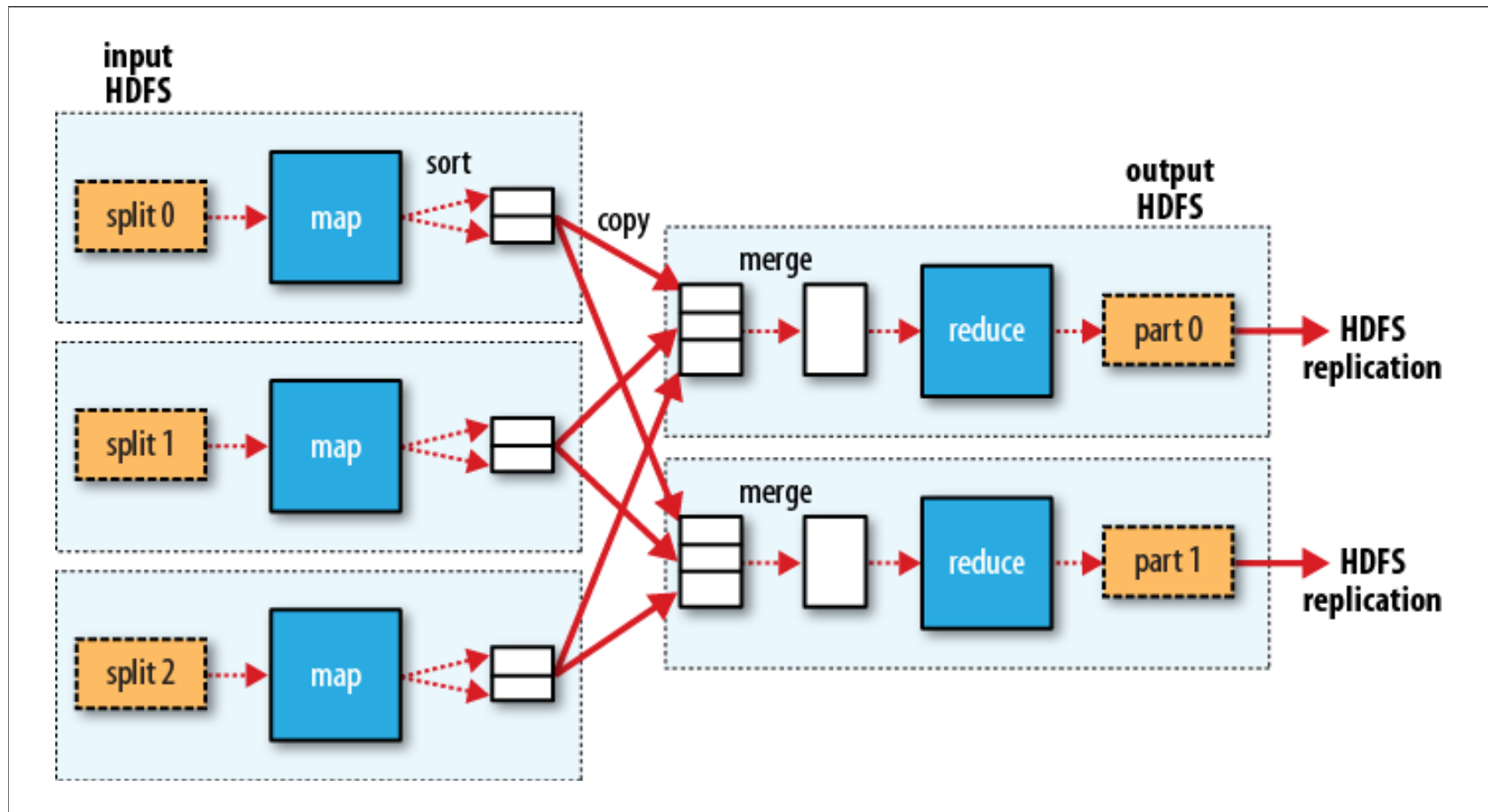

Partitioning

- Define a `Partitioner`
- Examines each `map ()` output pair
- Computes a partition number

Data Flow

Figure 4-2 from MapReduce Design Patterns

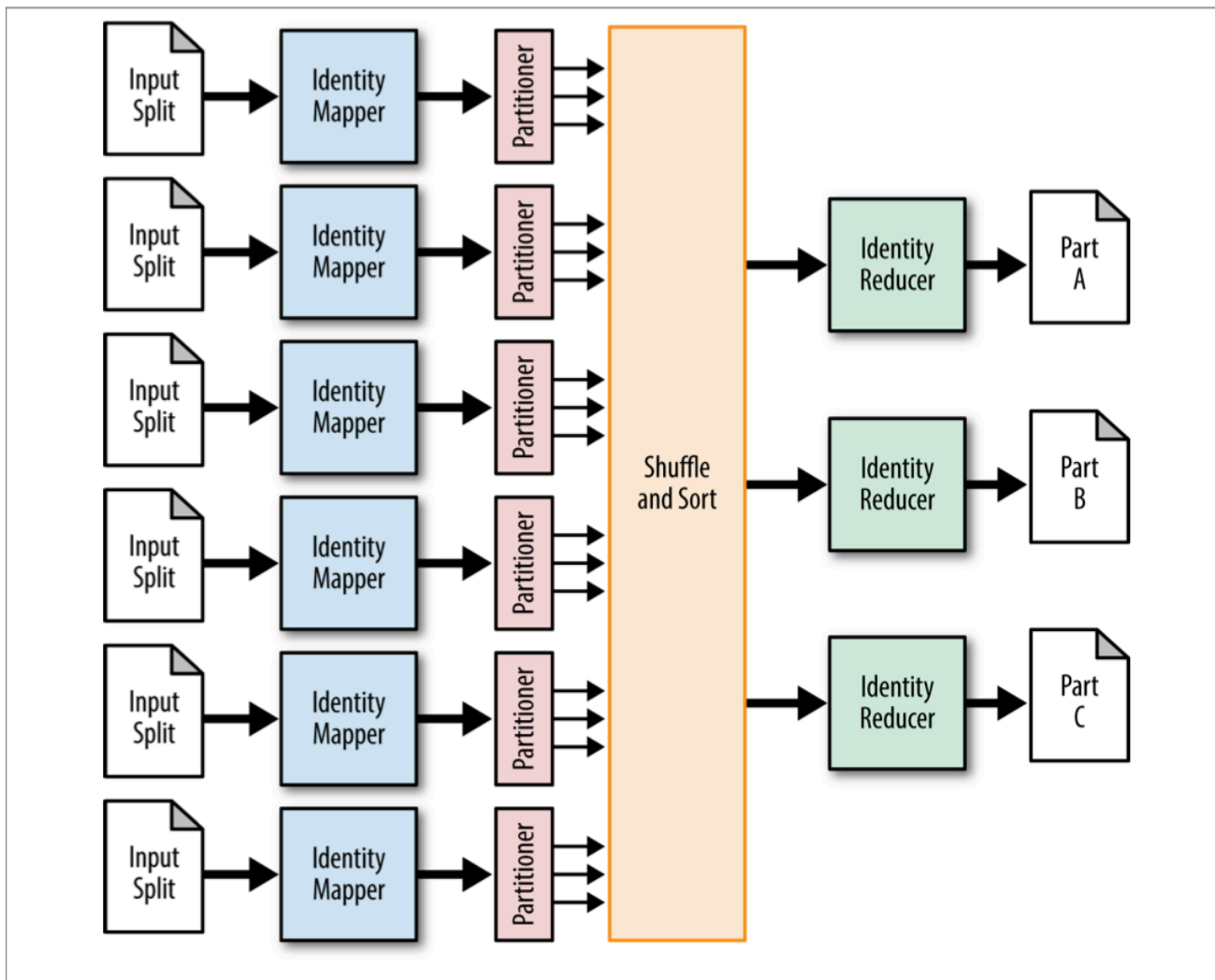

Binning

- Similar to partitioning
 - Want to organize output into categories
 - Map-only pattern (# reduce tasks set to 0)
- Mapper output written to output directories
- Uses `MultipleOutputs` class
 - Call `write()` on `MultipleOutputs`, **not** `Context`
 - For each category, each mapper writes a file
 - Expensive if many mappers and many categories

Binning Data Flow

Figure 4-3 from MapReduce Design Patterns

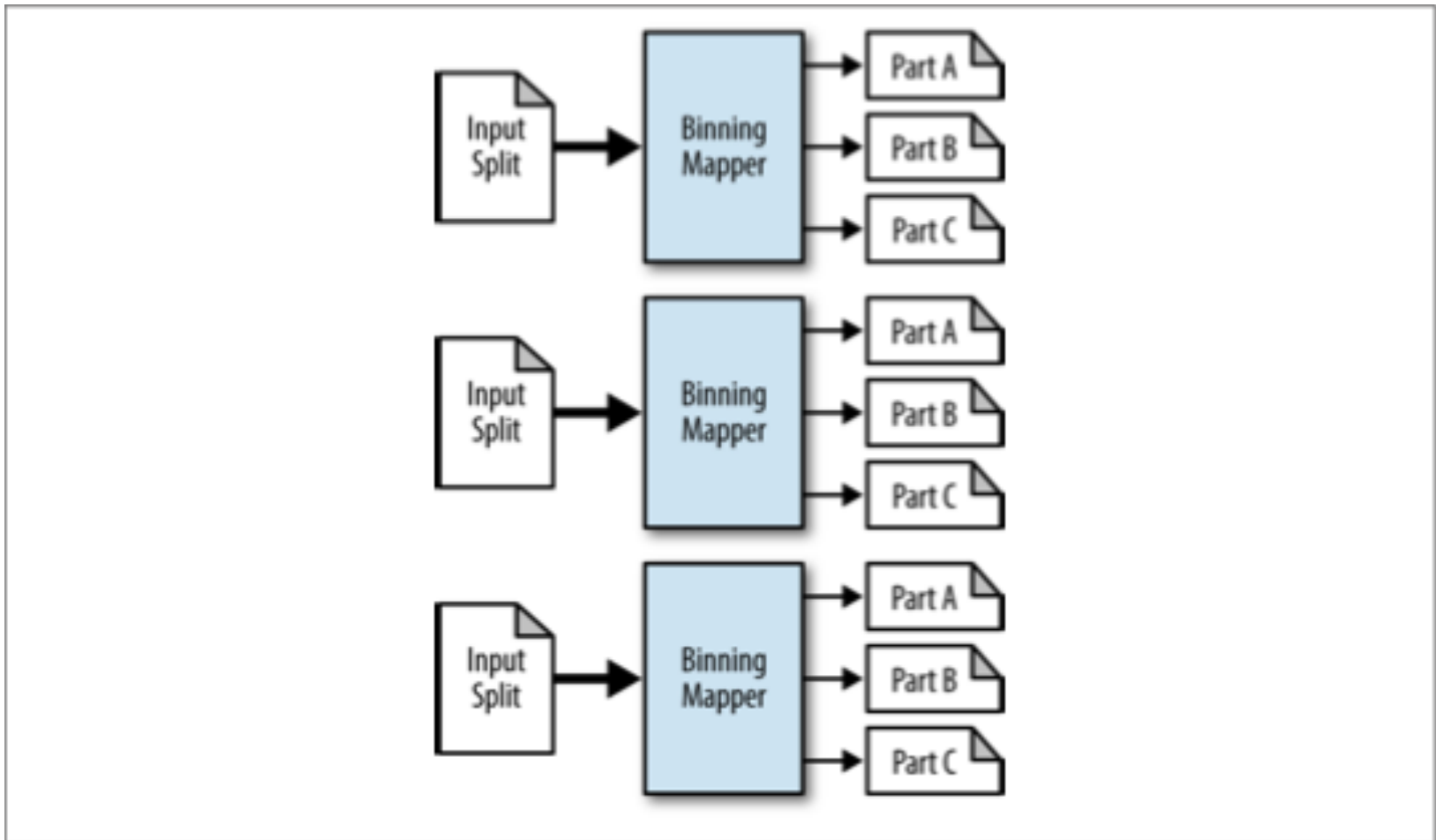

Discussion

- When should we use partitioning?
- When should we use binning?
- Consider the user sessions we've created

Shuffle

- Want to distribute output randomly
- Mapper generates a random key for each output
- If you want to reuse a mapper, you could add a partitioner that generates a random partition #
 - Mapper code is then unchanged
- Reducer can sort based on some other random key
 - Further shuffling the data (input order now gone)

Shuffle – Why Do This?

- Random sampling
- Randomly select subset of the data (downsample)
- Multiple random subsets for
 - Model generation and testing – cross validation
 - Train on 80%, test on 20%, for 5-fold cross validation
- Anonymizing data (example from the textbook)
 - Replace PII with a random key

Discussion

- Suppose we wanted to shuffle our user sessions
- When could we accomplish this in the process of creating sessions?

MapReduce in Hadoop

Figure 2.4, Hadoop - The Definitive Guide

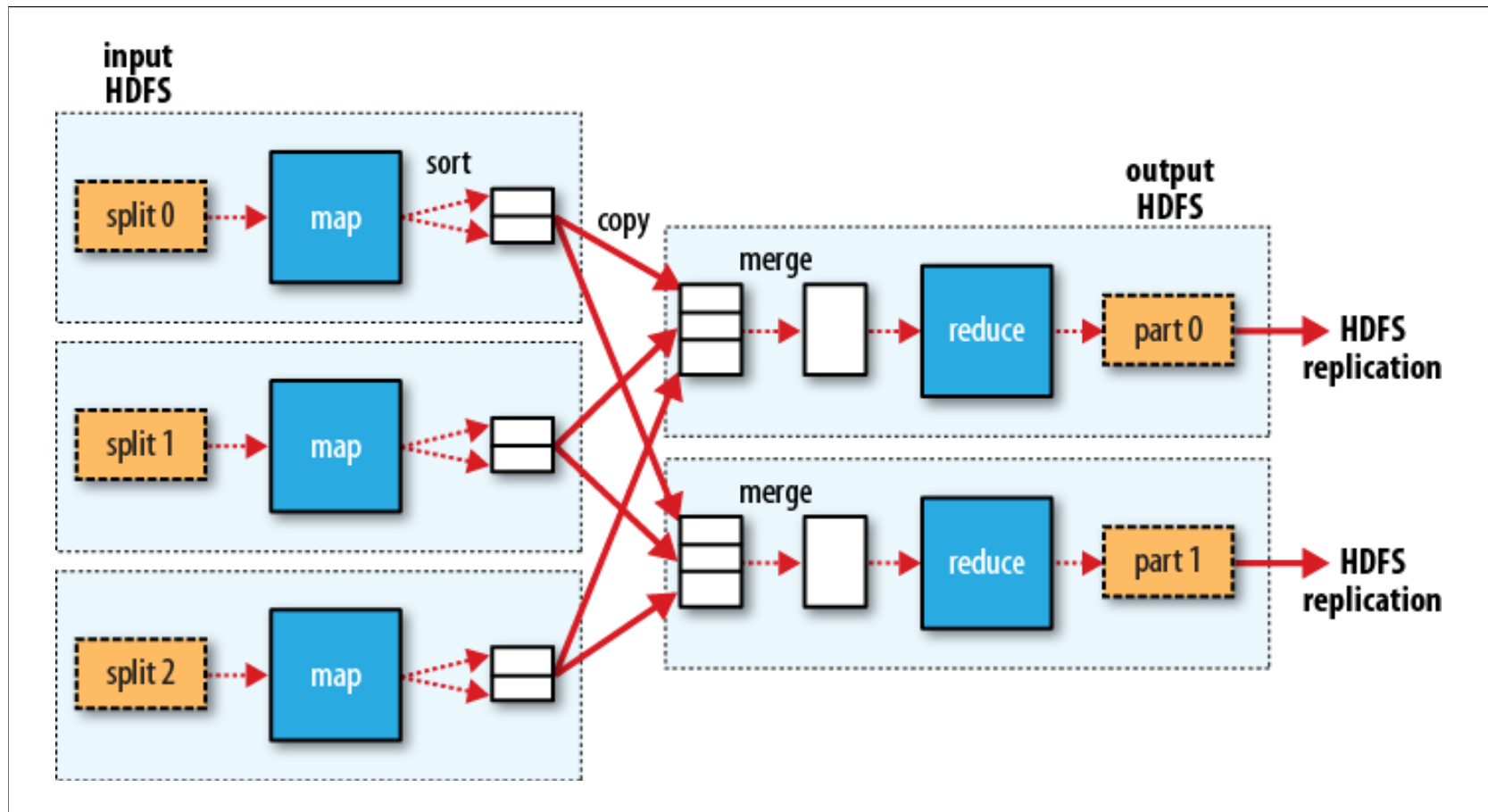

Total Order Sorting

- Individual reducers can sort their keys
 - Need to retain all data in memory
 - Not sorted when concatenated with other reducer output
- We can identify subranges of the key space
 - We know the sort position of each subrange relative to other subranges
 - Use a partitioner to assign a key to its subrange
 - Reducer simply outputs the values. Why?

Total Order Sorting

- Issues in selecting subranges of the key space
- Would like subranges to be roughly equivalent in size
 - Can do an analysis of the key space by random sample
 - Will be a separate mapReduce job
 - Need to redo this analysis if key distribution changes
- Subrange ideas for our session key space?

Total Order Sorting

- Hadoop provides `TotalOrderPartitioner`
- Have to provide a “partition file”
 - Specifies the key range of each partition
 - Number of reducers must equal number of partitions
- Custom partitioner for our user session key space
 - Based on `userId`
 - Other data to use for sort?